

drwg. no.: 1500-G	
date:	drwg.:
model:	scale:
drw. rev.:	material:

Type 1,2 and 3G

Automatic weightloaded pressure/vacuum valve

8	12	340	445	445	370	205	440	795	355	1150	355
8	8	340	340	390	315	175	425				
6	10	285	395	390	365	135	370	665	295	960	295
6	8	285	340	370	325	135	370	660	295	960	295
5	6	250	285	290	320	100	310				
4	8	220	340	250	285	150	300	535	230	760	230
4	6	220	285	260	285	120	300	530	225	750	225
3	5	200	250	200	230	100		460	210	670	210
3	4	200	220	190	230	95		450	210		
°d inch	°D inch	E mm	F mm	H mm	K mm	M mm	L-mm 1G	P-mm 2G	C-mm 2G	L-mm 3G	C-mm 3G

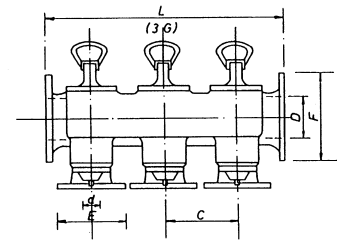
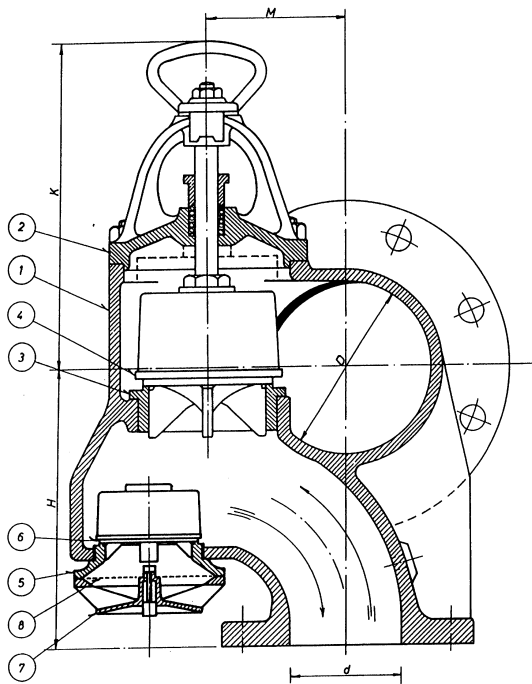

Opening standard:

- Pressure: 1400 mm W.G.
- Vacuum: 350 mm W.G.

Approved by:
Lloyds Register of Shipping
Det Norske Veritas
American bureau of Shipping
Bureau Veritas

Parts list

Item	Description	Spec. 1	Spec. 2
1	Valve body	Cast iron	Cast iron
2	Top cover	Cast iron	Cast iron
3	Pressure seat	Bronze	Stainless steel
4	Pressure disc	Bronze	Stainless steel
5	Vacuum seat	Bronze	Stainless steel
6	Vacuum disc	Bronze	Stainless steel
7	Venting cover	Bronze	Bronze
8	Protecting screen	Stainless steel	Stainless steel

This drawing is for guidance only. Other sizes, materials, flange standards, settings, and versions are available. Request a specific quotation or approval drawing before implementing data.