

drwg. no.:	1500-PHE
date:	drwg.:
model:	scale:
drw. rev.:	material:

Type PHE

Automatic weightloaded pressure/vacuum valve

10	250	800	270	260	415	395	350	12x22
8	200	820	250	240	350	340	295	8x22
7	175	750	230	230	265	315	270	8x22
6	150	675	200	200	255	285	240	8x22
5	125	600	165	165	245	250	210	8x18
4	100	545	140	140	235	220	180	8x18
$\varnothing d$ inch	$\varnothing d$ mm	H mm	B mm	C mm	L mm	$\varnothing D$ mm	P-mm drilling	Holes drilling

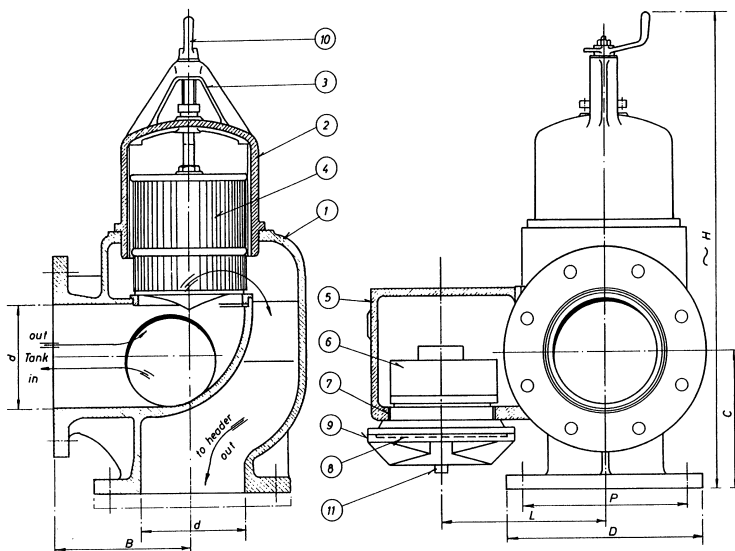

Opening standard:
 Pressure: 1400 mm W.G.
 Vacuum: 350 mm W.G.

Approved by:
 Lloyds Register of Shipping
 Det Norske Veritas
 Bureau Veritas
 American bureau of Shipping

Parts list

Item	Description	Spec. 1	Spec. 2
1	Valve body	Bronze	Cast iron
2	Pressure house	Bronze	Bronze
3	Top cover	Bronze	Bronze
4	Pressure disc	Bronze	Cast iron
5	Vacuum house	Bronze	Stainless steel
6	Vacuum disc	Bronze	Bronze
7	Vacuum seat	Bronze	Bronze
8	Protecting screen	Stainless steel	Stainless steel
9	Vacuum guard	Bronze	Bronze
10	Handle	Steel	Steel
11	Check lift, optional	Brass	Brass

This drawing is for guidance only. Other sizes, materials, flange standards, settings, and versions are available. Request a specific quotation or approval drawing before implementing data.