

drwg. no.: 2247	
date: 741704	drwg.: HHP
model: -	scale: -
drw. rev.: 1	material: -

Type ORE-OIL

Automatic weightloaded pressure/vacuum valve

8	200	915	400	360	340	295	8x22
°d inch	°d mm	A mm	B mm	H mm	°D mm	P-mm drilling	Holes

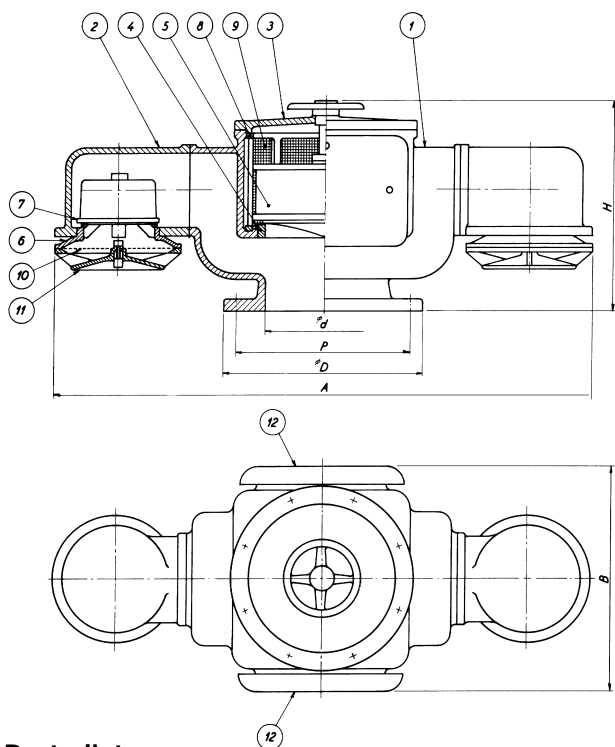

Opening standard:

- Pressure: 1400 mm W.G.
- Vacuum: 350 mm W.G.

Approved by:
 Lloyds Register of Shipping
 Det Norske Veritas
 Bureau Veritas
 American bureau of Shipping

Parts list

Item	Description	Spec. 1		
1	Valve body	Cast iron		
2	Vacuum house	Cast iron		
3	Top cover	Cast iron		
4	Pressure seat	Bronze		
5	Pressure disc	Bronze		
6	Vacuum seat	Bronze		
7	Vacuum disc	Bronze		
8	Netring	Bronze		
9	Protecting screen	Stainless steel		
10	Protecting screen	Stainless steel		
11	Venting cover	Bronze		
12	Venting cover	Cast iron		

This drawing is for guidance only. Other sizes, materials, flange standards, settings, and versions are available. Request a specific quotation or approval drawing before implementing data.