

drwg. no.: 2273	
date:	drwg.:
model:	scale:
drw. rev.:	material:

Type VF

Flame arrester for vertical discharge

8	200	390	295	340	295	8x22
6	150	340	255	295	240	8x22
4	100	260	235	220	180	8x18

^oD inch ^oD mm ^oA mm H mm ^oF mm P-mm Holes drilling

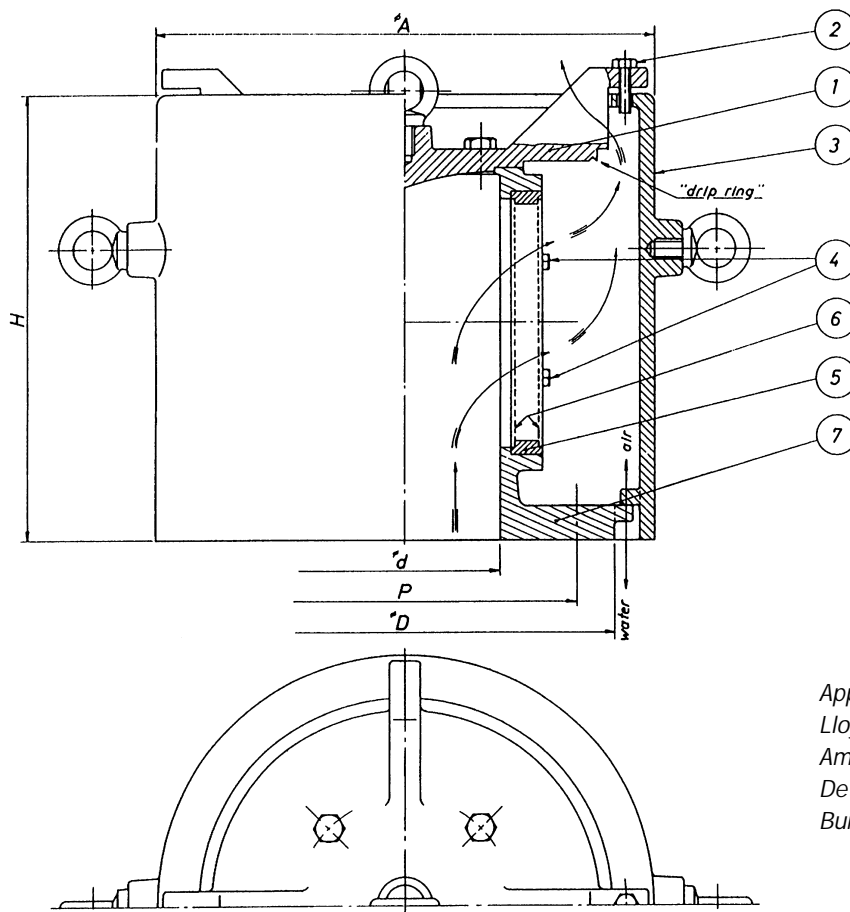

Approved by:
 Lloyds Register of Shipping
 American bureau of Shipping
 Det Norske Veritas
 Bureau Veritas

Parts list

Item	Description	Spec. 1	Spec. 2	Spec. 3
1	Top flange	Cast iron		
2	Locking bolt	Brass		
3	Casing	Cast iron		
4	Stopscrew for pos. 5	Brass		
5	Netring	Cast iron		
6	Double protecting screen	Stainless steel		
7	Flange casing	Cast iron		

This drawing is for guidance only. Other sizes, materials, flange standards, settings, and versions are available. Request a specific quotation or approval drawing before implementing data.